

REVISIONS				
LTR	BY	DESCRIPTION	DATE	APPROVED
B	VT	REVISED CABLE TO SHOW MANUFACTURING DONE BY BOTH COMOSS AND TWO TECH.	9-10-98	VT
C	VT	ADDED ITEM 10 SHRINK TUBING 10351 AND ITEM 11 FERRULE 13948 TO DWG AND BOM. ALSO NOTES 5 & 7.	3-23-04	VT
D	VT	CABLE 14163 IS NEW BASE CABLE.	12-8-04	VT

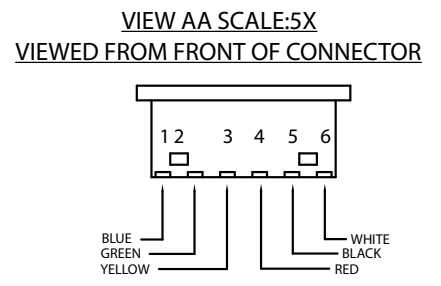

- NOTES:
1. DRAWING MUST BE PLOTTED IN COLOR
 2. USE MOLEX CRIMP DIE NO. 11-40-2245 TO BE USED WITH MOLEX PRESS TW42, OR HAND TOOL 57177-5000 TO CRIMP TERMINAL TO WIRE.
 3. GROMMET MUST PASS PULL TEST OF 43LBS @ 1 MINUTE.
 4. CABLE MUST PASS ELECTRICAL TEST PRIOR TO SHIPPING.

- PIN 1 BLUE (COMMON)
- PIN 2 GREEN (RX(-)RXD))
- PIN 3 YELLOW (TXD(+))
- PIN 4 RED (DTR(+))
- PIN 5 BLACK (DS(-)RXD))
- PIN 6 WHITE (+ SUPPLY)

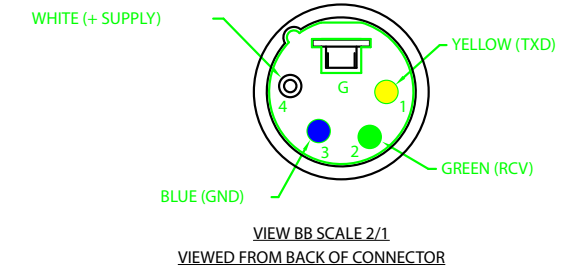
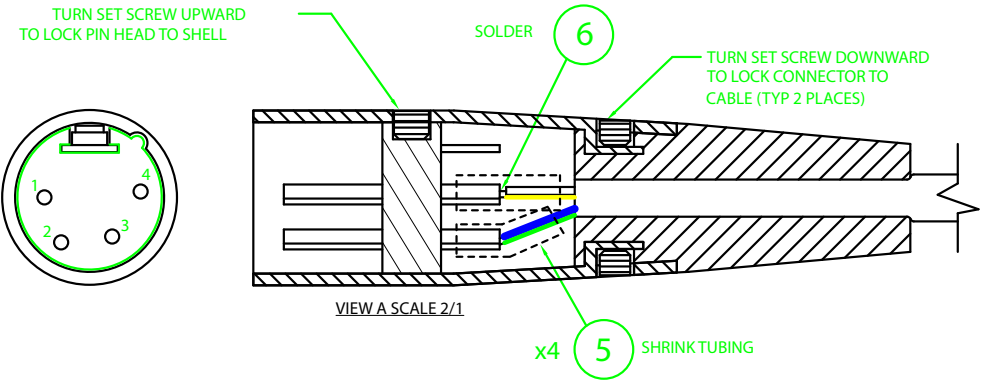
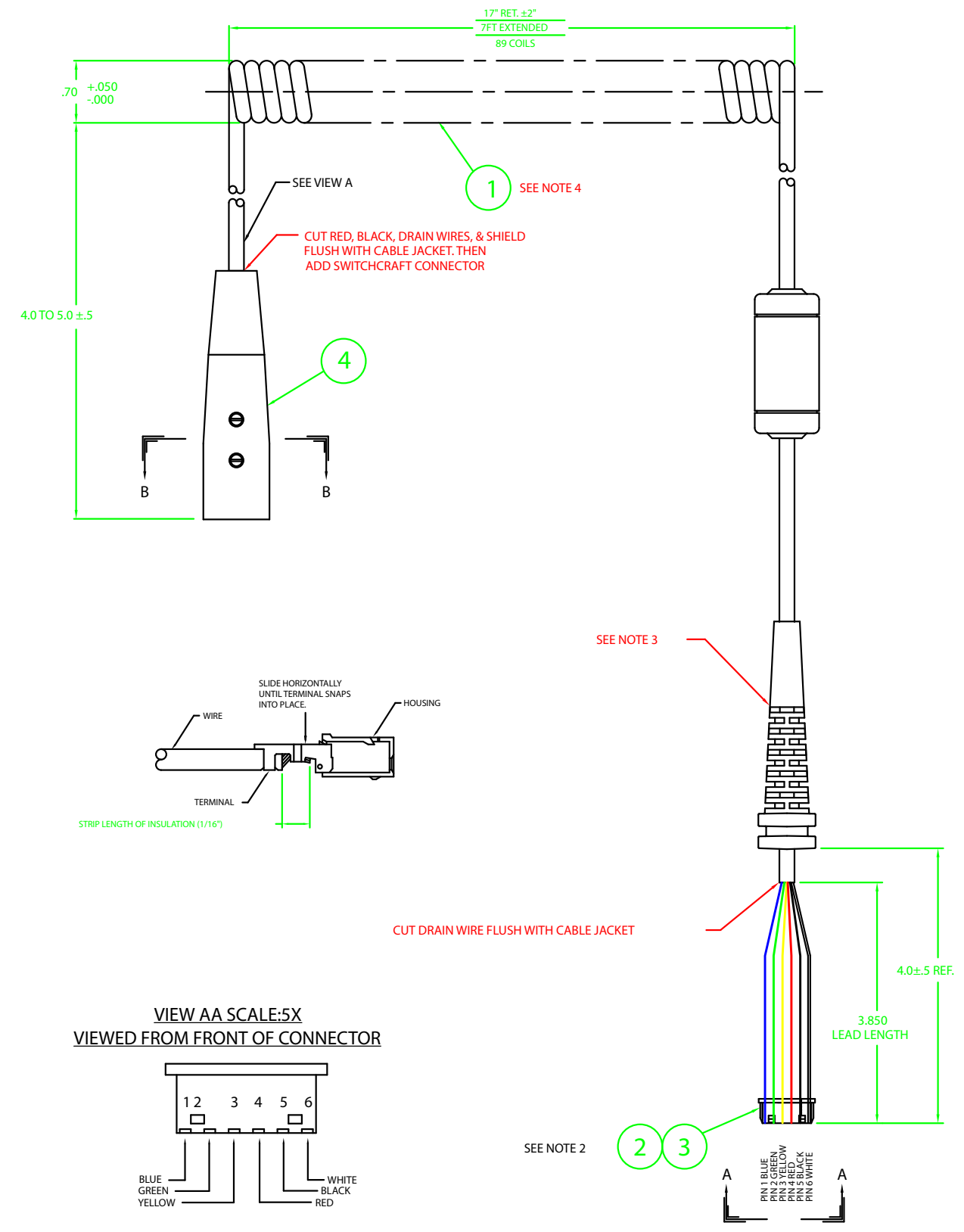