

REVISIONS				
LTR	BY	DESCRIPTION	DATE	APPROVED
B	VT	FIXED LEAD LENGTH FROM 4" TO 9"	6-16-98	VT

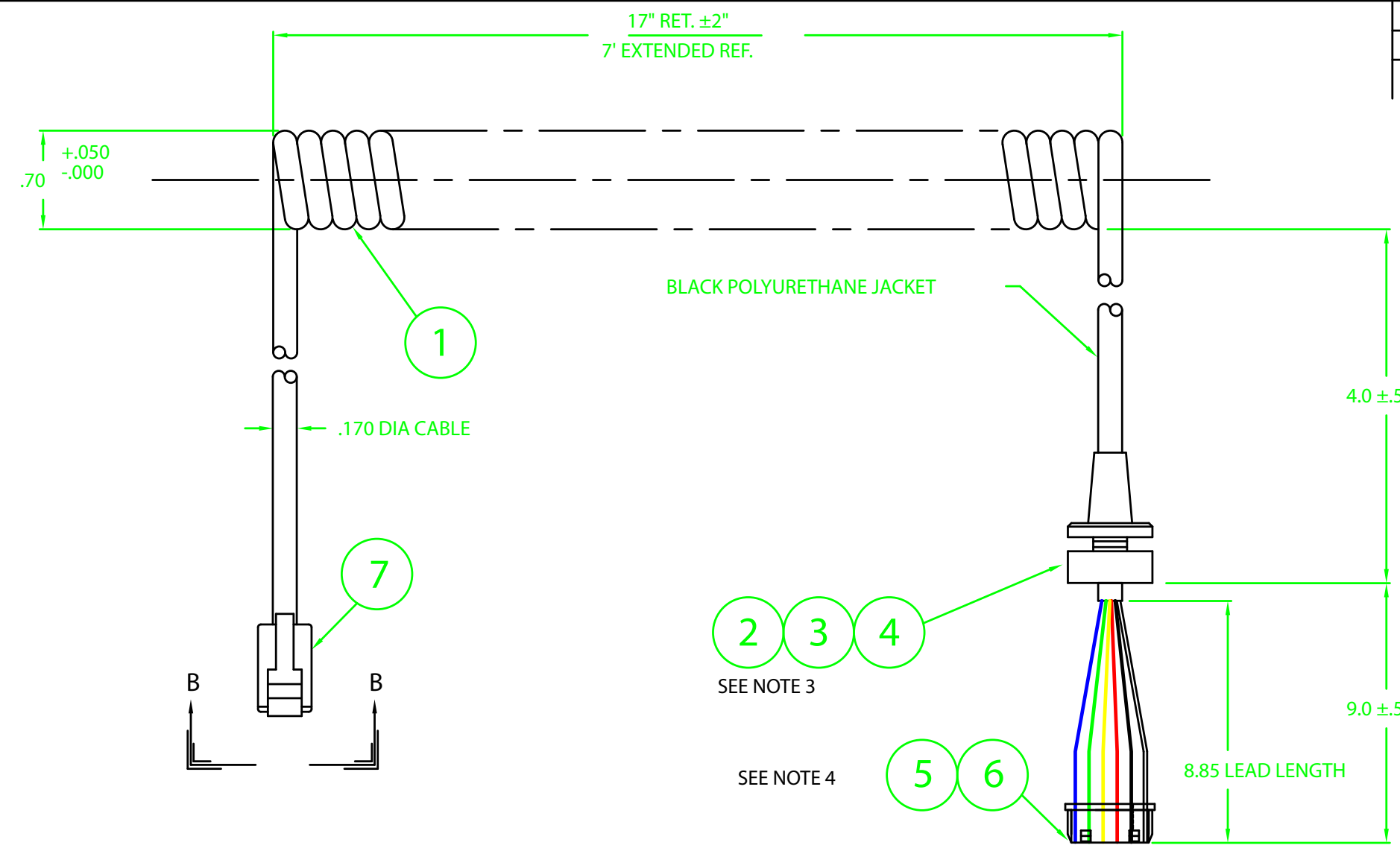

- PIN 1 BLUE (COMMON)
- PIN 2 GREEN (RX(+)-RXD))
- PIN 3 YELLOW (TXD(+)-TX)
- PIN 4 RED (DTR(+)-XD))
- PIN 5 BLACK (DS(+)-RXD))
- PIN 6 WHITE (+ SUPPLY)

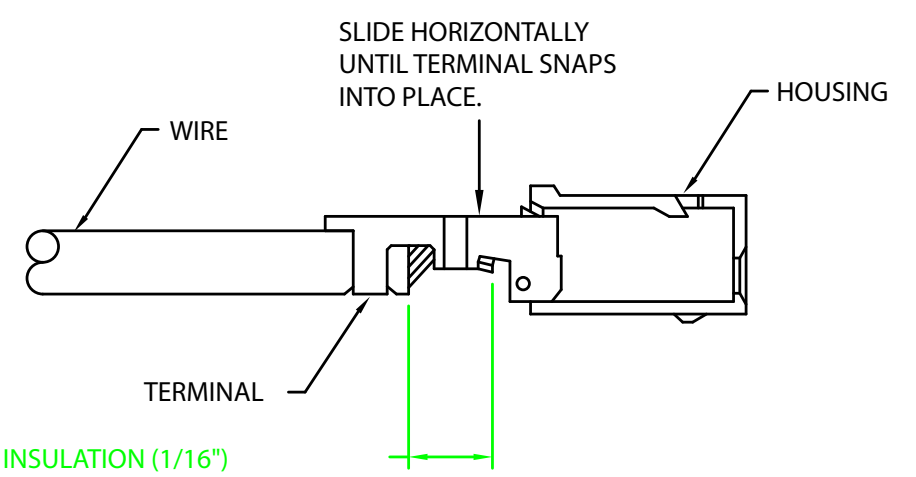
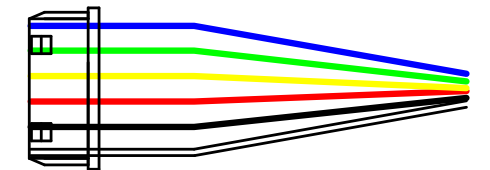

STRIP LENGTH OF INSULATION (1/16")

- NOTES:
1. DRAWING MUST BE PLOTTED IN COLOR
 2. JACKET IS BLACK POLYURETHANE
 3. EQUIVALENT ADHESIVE MAY BE USED
 4. USE MOLEX CRIMP DIE NO. 11-40-2245 TO BE USED WITH MOLEX PRESS TW42, OR HAND TOOL 57177-5000 TO CRIMP TERMINAL TO WIRE.

VIEW BB SCALE:6X
VIEWED FROM FRONT OF RJ-11

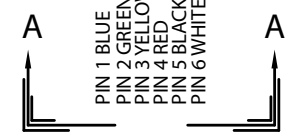
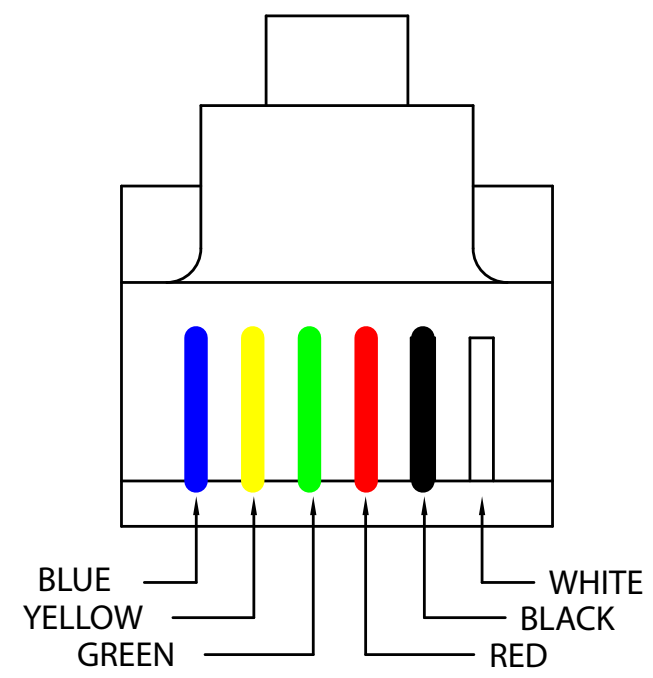

VIEW AA SCALE:5X
VIEWED FROM FRONT OF CONNECTOR

